

# Table of Contents

Each Rollease Acmeda battery & plug-in motor will come preprogrammed from the factory. The preprogrammed assures the remote is paired with the motor, the upper and lower operation limits are set, the remote is locked and the unnecessary channels are hidden for ease of use (15 available).

1. Remote Overview
2. Initial Setup Programming
2. Sleep Mode
3. Remote & Motor Pairing
4. Reverse Motor Direction
5. Mirroring Remotes
6. Adjusting Limits
7. Tilt Mode
8. Hiding/Unhiding Remote Channels
9. Favorite Positions
10. Group Control
11. Reset to Factory Settings
12. Troubleshooting

# Remote Overview

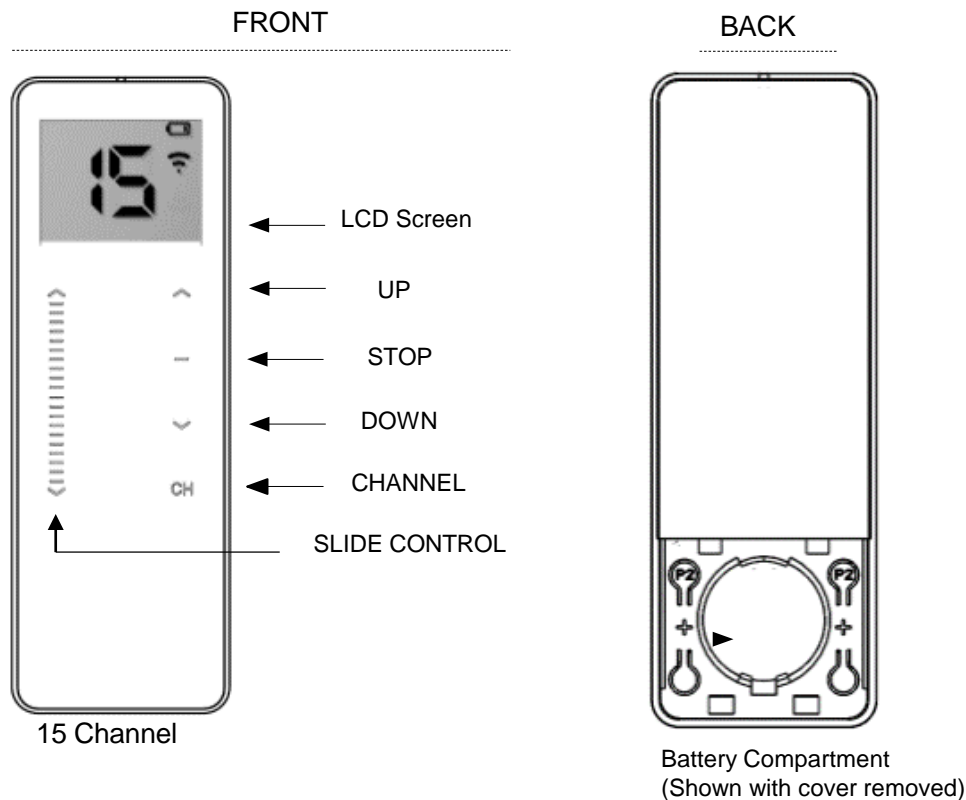

TECHNICAL SPECIFICATIONS	
Voltage:	3V (CR2450)
Frequency:	433.92 MHz
Transmitting Power:	10 milliwatt
Ambient Operating Temperature:	-10°C - 50°C
Transmission Distance:	Up to 200 meters (open space)
Battery:	CR2450

## FEATURES

- Touch sensitive controls
- Levelling control (15 Channel Remote)
- LCD Display (15 channel Remote)
- Hide unused channels function
- Slim magnetic wall mount holder

## PACKAGE CONTENTS

- Remote
- Magnetic holder & fixing screws
- Instruction Manual
- 3V - CR2450 Battery

## INSTALL WALL MOUNT HOLDER

**1** Remove cover from base by prying with flat head screwdriver

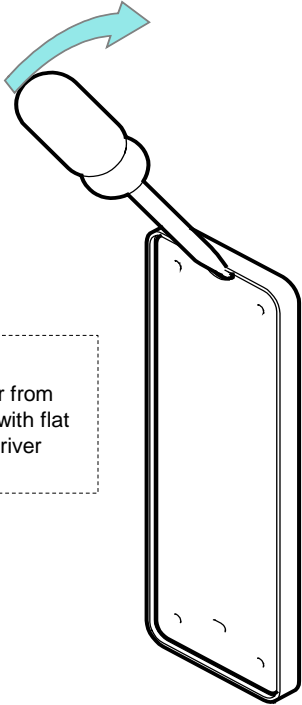

**2** Use supplied fasteners and anchors as needed to attach base to desired surface as shown in figure

Assure screwdriver slot is facing up or the remote will not be held in place securely

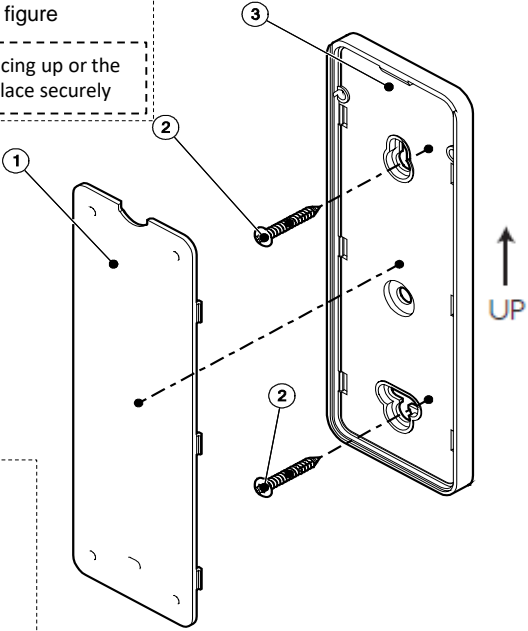

**3** Replace cover by pressing snap latches into place

## INSTALL AND/OR REPLACE REMOTE BATTERY

**1** Remove cover from remote: with 2 fingers placed in upper area of cover, press gently in and down to disengage cover and slide down to remove

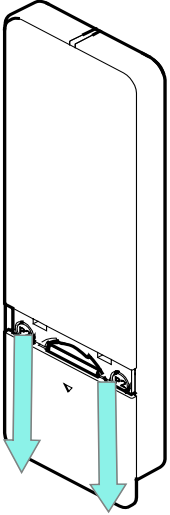

**2** Install battery with positive(+) side facing up

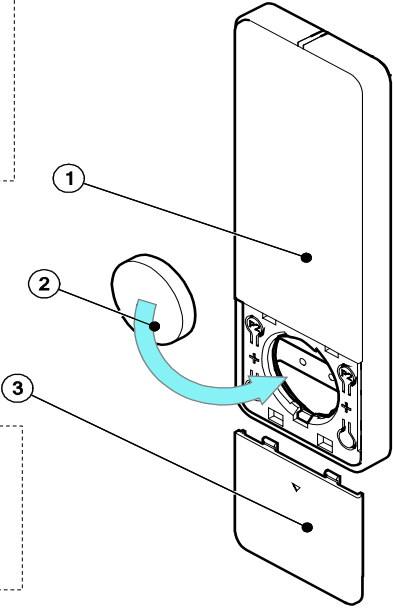

**3** Replace cover by reversing step 1

BOM ID	Description	Qty
1	CR2450 Battery	1
2	Cover	1
3	Remote	1

# Initial Setup Programming

## 1. SELECT CHANNEL TO BE PAIRED

**Detail View of Remote Controls**

**1a**

Press any button to wake remote.

Hold **CH (1sec)** LCD screen will flash to confirm.

**1b**

Within 4sec Press **UP** or **DOWN** to select desired channel.

**1c**

Press **STOP** to confirm selection OR remote will auto confirm after 4sec.

## 2. PAIRING REMOTE TO MOTOR

**ACTIVATE PAIRING MODE ON MOTOR**

**2a (Any Motor)**

Press & HOLD Programming button on motor head (2sec)

PROGRAMMING BUTTON

PROGRAMMING BUTTON - RECESSED

Note: Programming buttons will face down when shade is installed

**Motor Response**

Approx. 2 SECS

EXT. BEEP X1

JOG X1

---

**PAIRING REMOTE**

**2b**

Within 4sec of activating pairing mode, Press & Hold **STOP**

**Motor Response**

Approx. 2 SECS

BEEP X3

JOG X2

If you do not pair the remote in time the motor pairing sequence will time out, repeat the above steps assuring to press and hold the STOP button within 4 seconds of the motor jog

# Initial Setup Programming

## 3. Unlock/Lock Remote (Limit Setting Mode)

If limits need adjusting, follow the instructions below to unlock the remote for limit setting:

- Unlock the limit setting tool by pressing the right P2 button on the back of the remote (remove cover to expose the button)
- Press and hold the button until the LED display shows a flashing "U", then release.
- You will be required to set the remote back into "limit locking mode" once final adjustments have been made. Simply repeat the above step until a flashing "L" shows on the display ("U" for unlocked, "L" for locked).

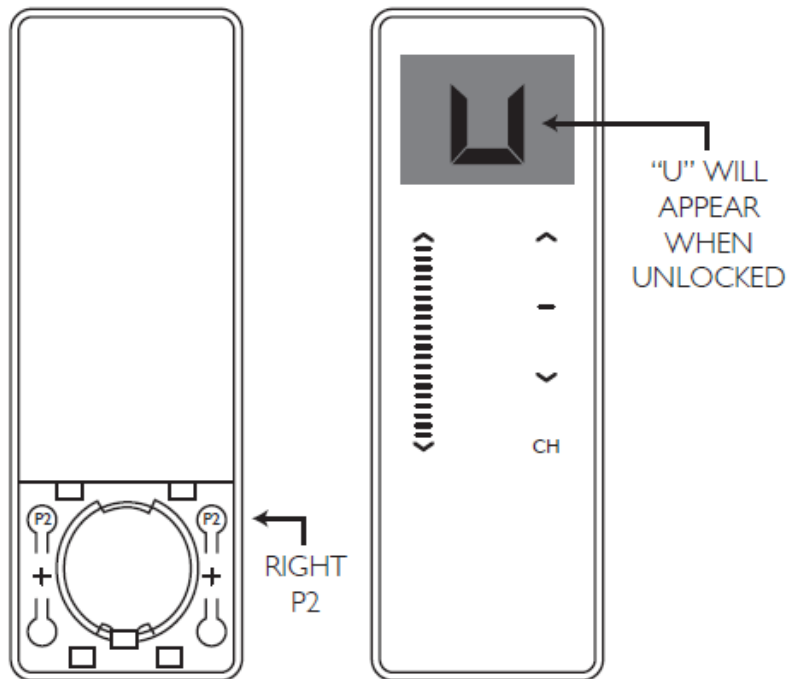

# Initial Setup Programming

## 4. Reverse Motor Direction If Required (Options A or B)

### Option A - REMOTE OPERATION

(Only Possible During Initial Setup Or After Factory Reset Before Limits Are Set)

To check motor direction, quickly press the UP or DOWN button to move the shade initially. Press STOP to pause the shade operation.

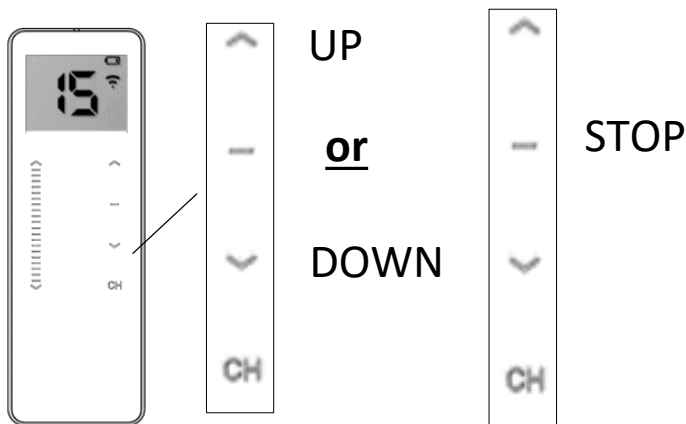

IF DIRECTION DOES NOT ALIGN WITH UP/DOWN BUTTONS – Press and hold down the UP and DOWN button simultaneously until the motor jogs UP and DOWN once.

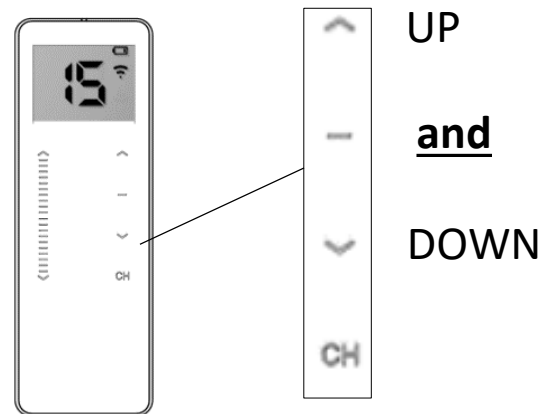

Motor Response



### Option B - MOTOR OPERATION (Possible At Any Time)

Hold Programming Button (10 sec)

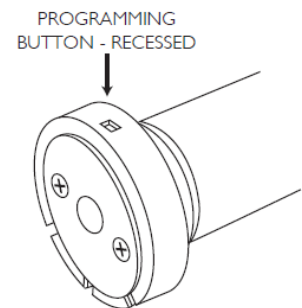
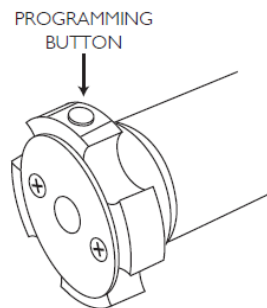
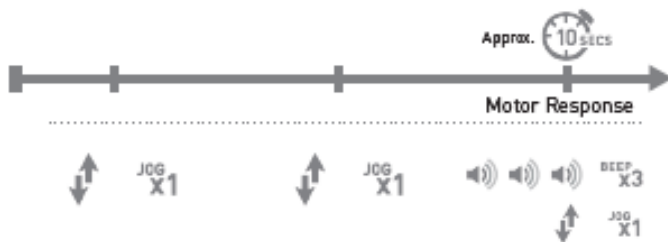

Note: Programming buttons will face down when shade is installed

# Initial Setup Programming

## 5. Setting Limits

### SETTING UPPER/LOWER LIMITS

**Important!!** Stop the shade prior to traveling past the desired position or damage to the product can occur

Drive the shade using continuous movement or fine adjust to the position you wish to set as the upper limit. Set limit as described below. 3 beeps from the motor will confirm the limit is saved. Repeat the same process to drive to and set the lower limit.

#### (To SET Top Limit)

Press **UP + STOP (3sec)**

Motor Response



#### (To SET Bottom Limit)

Press **DOWN + STOP (3sec)**

Motor Response



**!!WARNING!!** - Move shade in short increments by pressing the UP/DOWN button in 1 second intervals (pressing the UP/DOWN button for more than 3 seconds may send the shade past desired upper/lower limit and may result in damage to the product). Once you have reached the desired upper/lower limit, you can adjust the limit with either the UP and DOWN buttons. (remember to adjust in short increments!)

**Important!!** Remember to return the remote control to "L" mode as previously described to prevent inadvertent shade adjustment during normal operation and remote handling.

# Sleep Mode

Each Rollase Acmeda battery & plug-in motor will come preprogrammed from the factory. Upon leaving the factory the motor is placed into “Sleep Mode” to avoid accidental operation during shipping.

It is necessary to “Wake” the motor before operation and setup.

## Exit Sleep Mode

To “Wake” the motor and exit Sleep Mode assure the motor is installed and secured in the mounting hardware.

Press the programming button (button or recessed based on motor size) and quickly release. The motor is now no longer in “Sleep Mode” and ready for further setup.

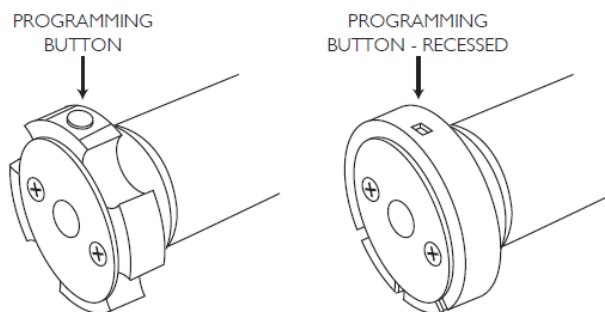

Note: Programming buttons will face down when shade is installed

## Enter Sleep Mode

If required, to place the motor back into “Sleep Mode” press and hold the programming button for a period of 6 seconds. Release the button when the motor has jogged up and down twice. The motor will beep twice to signify “Sleep Mode” has been activated.

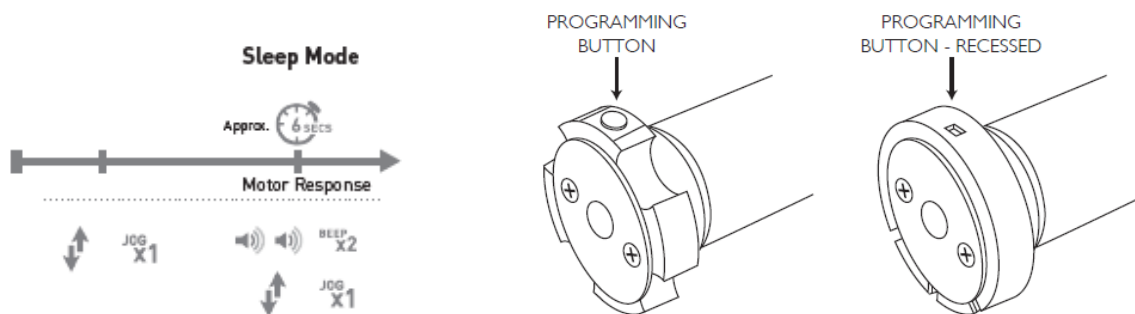

Note: Programming buttons will face down when shade is installed



# Remote + Motor Pairing

Each Rollease Acmeda battery & plug-in motor will come preprogrammed from the factory. The preprogramming assures the remote is paired with the motor, the upper and lower operation limits are set, the remote is locked and the unnecessary channels are hidden for ease of use (15 available).

Follow the below steps to select the remote channel you want to pair with the motor(s) if required at a later date.

## 1. SELECT CHANNEL

**Detail View of Remote Controls**

**1a**  
Press any button to wake remote.  
Hold **CH** (1sec) LCD screen will flash to confirm.

**1b**  
Within 4sec Press **UP** or **DOWN** to select desired channel.

**1c**  
Press **STOP** to confirm selection OR remote will auto confirm after 4sec.

## 2. PAIRING OR REMOVING MOTOR FROM A SPECIFIC CHANNEL

**ACTIVATE PAIRING MODE ON MOTOR**

**2a (Any Motor)**

Press & hold programming button on motor head (2sec)

PROGRAMMING BUTTON  
PROGRAMMING BUTTON - RECESSED

Note: Programming buttons will face down when shade is installed

**Motor Response**

Approx. 2 SECS  
EXT. BEEP X1  
JOG X1

---

**PAIRING OR REMOVING REMOTE**

**2b**

Within 4sec of activating pairing mode, Press & Hold **STOP**

**Motor Response**

Approx. 2 SECS  
BEEP X3  
JOG X2

If you do not pair the remote in time the motor pairing sequence will time out, repeat the above steps assuring to press and hold the STOP button within 4 seconds of the motor jog

# Reverse Motor Direction

Each Rollease Acmeda battery & plug-in motor will come preprogrammed from the factory. The preprogramming assures the remote is paired with the motor, the upper and lower operation limits are set, the remote is locked and the unnecessary channels are hidden for ease of use (15 available).

To reverse the motor direction at any time, use the motor operation method shown below.

## MOTOR OPERATION (Possible At Any Time)

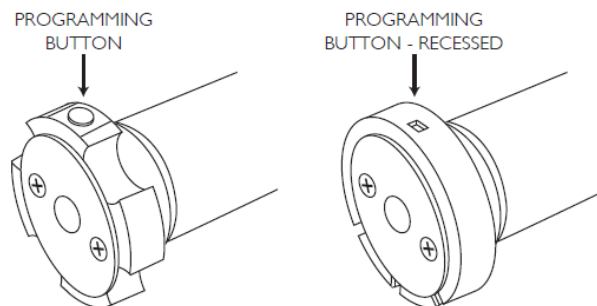
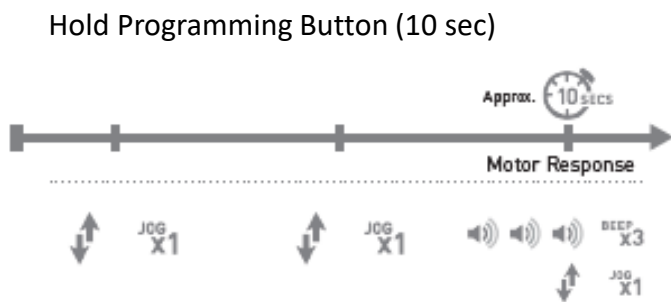

Note: Programming buttons will face down when shade is installed

# Mirroring Remotes

Each Rollese Acmeda battery & plug-in motor will come preprogrammed from the factory. The preprogramming assures the remote is paired with the motor, the upper and lower operation limits are set, the remote is locked and the unnecessary channels are hidden for ease of use (15 available).

Follow the below steps to copy settings from an existing remote to a new remote.

## 1. SELECT CHANNEL ON EXISTING REMOTE TO BE COPIED

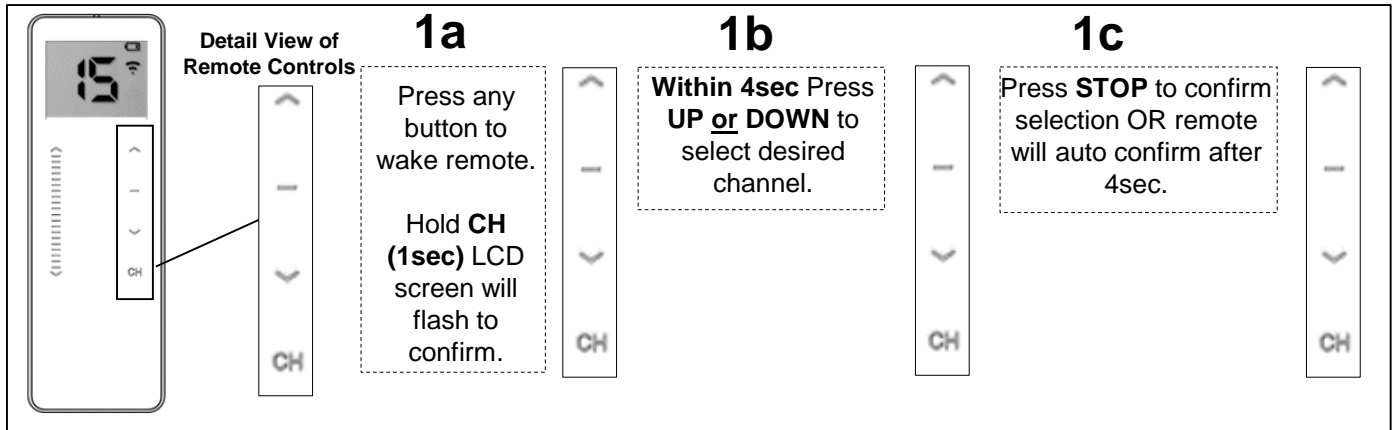

Note: Select channel on existing remote to be copied  
Select channel on new remote where existing channel will be copied

## 2. ADD OR REMOVE REMOTE USING AN EXISTING REMOTE

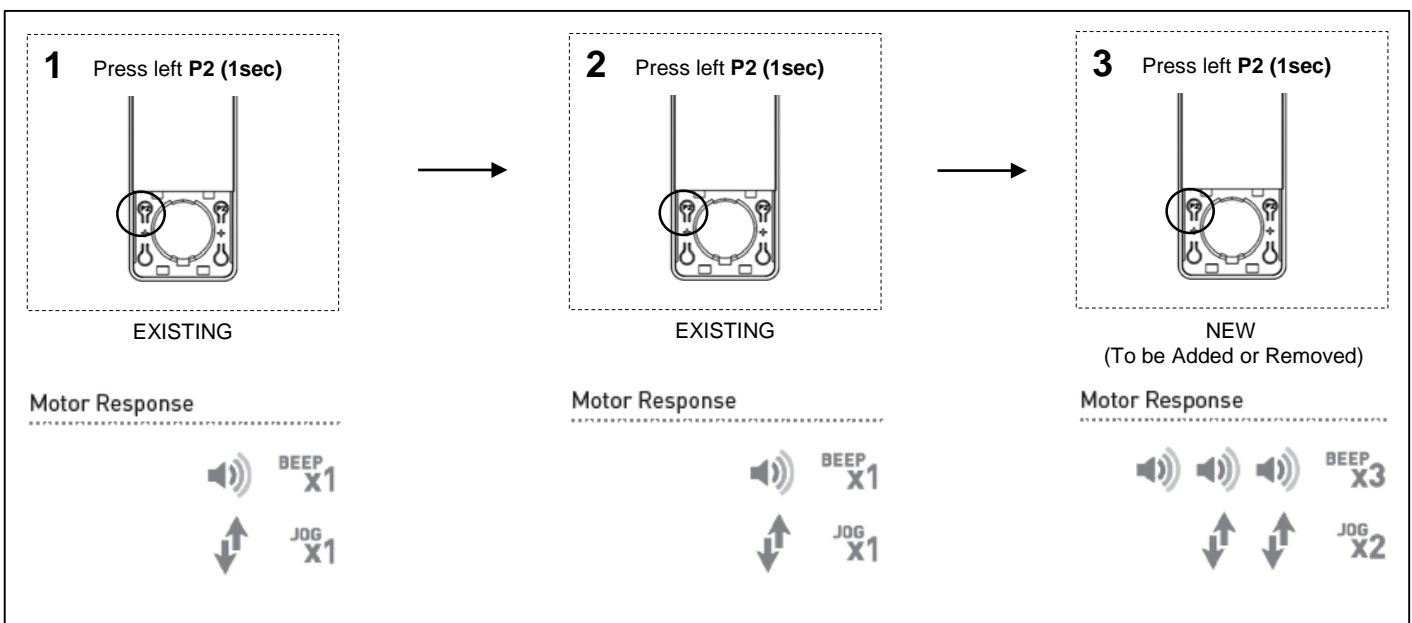

# Adjusting Limits

Each Rollease Acmeda battery & plug-in motor will come preprogrammed from the factory. The preprogramming assures the remote is paired with the motor, the upper and lower operation limits are set, the remote is locked and the unnecessary channels are hidden for ease of use (15 available).

Follow the below steps to adjust the upper and lower limits if required.

If limits need adjusting, follow the instructions below to unlock the remote for limit setting:

- Unlock the limit setting tool by pressing the right P2 button on the back of the remote (remove cover to expose the button)
- Press and hold the button until the LED display shows a flashing "U", then release.
- You will be required to set the remote back into "limit locking mode" once final adjustments have been made. Simply repeat the above step until a flashing "L" shows on the display ("U" for unlocked, "L" for locked).

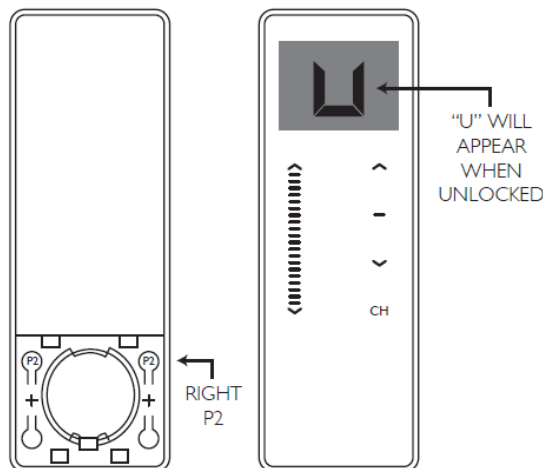

## ADJUSTING UPPER LIMIT

### (DELETE Top Limit)

Press UP & STOP (5sec)

Motor Response



Move the shade to the new desired position to be set as limit.

**Important!!** Stop the shade prior to traveling past the desired upper limit

### (SET Top Limit)

Press UP + STOP (5sec)

Motor Response

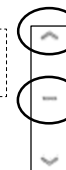

## ADJUSTING LOWER LIMIT

### (DELETE Lower Limit)

Press DOWN & STOP (5sec)

Motor Response



Move the shade to the new desired position to be set as limit.

**Important!!** Stop the shade prior to traveling past the desired lower limit

### (SET Lower Limit)

Press DOWN + STOP (5sec)

Motor Response

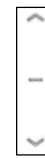

**!!WARNING!!** - Move shade in short increments by pressing the UP/DOWN button in 1 second intervals (pressing the UP/DOWN button for more than 3 seconds may send the shade past desired upper/lower limit and may result in damage to the product). Once you have reached the desired upper/lower limit, you can adjust the limit with either the UP and DOWN buttons. (remember to adjust in short increments!)

# Tilt Mode (Wood Blind Only)

Each Rollease Acmeda battery & plug-in motor will come preprogrammed from the factory. The preprogramming assures the remote is paired with the motor, the upper and lower operation limits are set, the remote is locked and the unnecessary channels are hidden for ease of use (15 available).

Follow the below steps to switch between tilt mode (incremental movement) or roller mode (drives to limits) on any motor. The motor must be paired to a remote and the remote must be unlocked to execute this procedure. Motors come programmed by default in roller mode.

If limits need adjusting, follow the instructions below to unlock the remote for limit setting:

- Unlock the limit setting tool by pressing the right P2 button on the back of the remote (remove cover to expose the button)
- Press and hold the button until the LED display shows a flashing "U", then release.
- You will be required to set the remote back into "limit locking mode" once final adjustments have been made. Simply repeat the above step until a flashing "L" shows on the display ("U" for unlocked, "L" for locked).

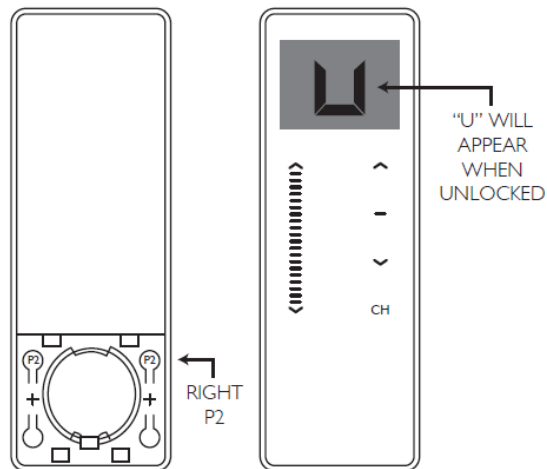

With the remote unlocked. Hold the UP and DOWN button on the controller for approximately 5 seconds. The motor will jog up and down once.

Immediately after the motor jogs, press and hold the STOP button. The motor will jog up and down and beep to confirm Tilt Mode has been entered.

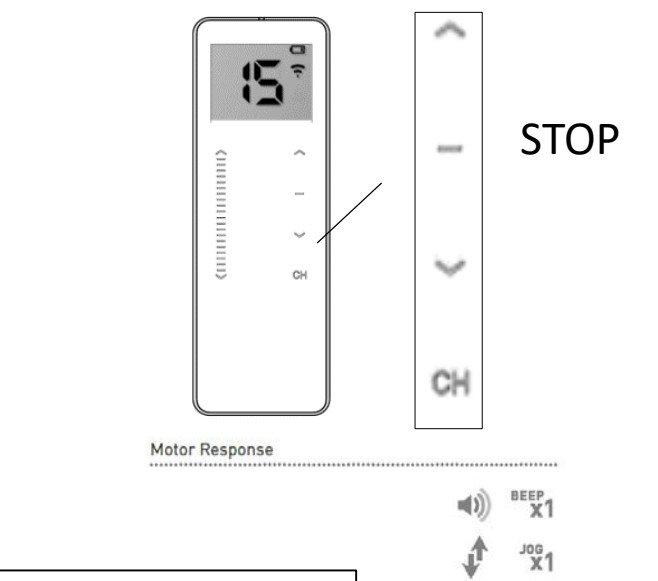
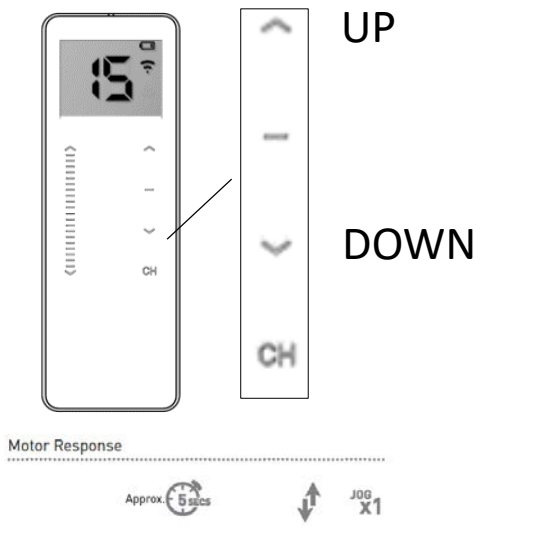

Repeat the above procedure to re-enter Roller Mode

If you do not activate tilt mode in time the motor programming sequence will time out, repeat the above steps assuring to press the STOP button within 4 seconds of the motor jog

# Hide/Unhide Remote Channels

Each Rollease Acmeda battery & plug-in motor will come preprogrammed from the factory. The preprogramming assures the remote is paired with the motor, the upper and lower operation limits are set, the remote is locked and the unnecessary channels are hidden for ease of use (15 available).

Follow the below steps to hide and unhide channels on the remote.

**1**

Press & Hold **STOP + CH**

Remote Response  
**LCD screen flashes**  
**"15" which defaults remote control to 15 visible channels**



**2**

Release only **STOP**

Keep **CH** pressed for the entire procedure

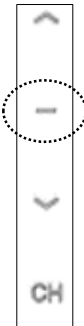

**3**

Press **UP or DOWN** to select number of active channels



**4**

Press **STOP**, then release **CH** to confirm

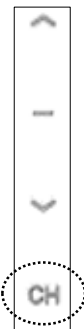







# Favorite Positions

Each Rollease Acmeda battery & plug-in motor will come preprogrammed from the factory. The preprogramming assures the remote is paired with the motor, the upper and lower operation limits are set, the remote is locked and the unnecessary channels are hidden for ease of use (15 available).

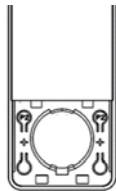
Follow the below steps to set a favorite position. The favorite position is used to set a custom stopping point between the upper and lower limits. (1 favorite position per shade motor)







To set a favorite position for a shade motor, drive to the desired position and press the STOP button to pause the drive operation.

## SETTING FAVORITE POSITION

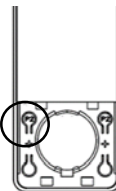
<p><b>1 (To Save Position)</b></p> <p>Press <b>UP</b> or <b>DOWN</b> to move shade to desired favorite position</p>	<p><b>2</b> Press left P2 (1sec)</p> 	<p><b>3</b> Press STOP (1sec)</p> 	<p><b>4</b> Press STOP (1sec)</p> 
	<p>Motor Response</p> 	<p>Motor Response</p> 	<p>Motor Response</p> 

- Press STOP (3sec) to move shade to the Favorite Position from any location
- Repeat Steps 1-4 for all additional motors

## DELETING FAVORITE POSITION

<p><b>1 (To Delete Position)</b></p> <p>Press <b>STOP (3 sec)</b> to send the shade to the stored favorite position.</p>	<p><b>2</b> Press left P2 (1sec)</p> 	<p><b>3</b> Press STOP (1sec)</p> 	<p><b>4</b> Press STOP (1sec)</p> 
	<p>Motor Response</p> 	<p>Motor Response</p> 	<p>Motor Response</p> 

# Group Control

Each Rollease Acmeda battery & plug-in motor will come preprogrammed from the factory. If multiple motors are paired to the same 15 channel remote, the 0 channel is the default channel to control all motors at once.

Follow the steps below to group motors on a specific channel for simultaneous control.

To custom define a channel to control multiple motors, pairing in groups can be executed. This will allow you to operate a series of motors in unison without needing to change channels. Each motor to be grouped must be paired with the remote on its own channel prior to grouping.

## 1. SELECT CHANNEL TO BE PAIRED AS A GROUP

**Detail View of Remote Controls**

Press any button to wake remote.

Hold **CH** (1sec) LCD screen will flash to confirm.

**Within 4sec** Press **UP** or **DOWN** to select desired channel.

Press **STOP** to confirm selection OR remote will auto confirm after 4sec.

## 2. PAIRING REMOTE TO MOTOR

(Repeat for all motors to be added or removed from your desired group channel.)

**ACTIVATE PAIRING MODE ON MOTOR**

(Any Motor)

Press & hold P1 button on motor head (2sec)

PROGRAMMING BUTTON

PROGRAMMING BUTTON - RECESSED

Note: Programming buttons will face down when shade is installed

**Motor Response**

Approx. 2 SECS

EXT. BEEP X1

JOG X1

---

**PAIRING REMOTE**

Within 4sec of activating pairing mode, Press & Hold **STOP**

**Motor Response**

Approx. 2 SECS

BEEP X3

JOG X2

If you do not pair the remote in time the motor pairing sequence will time out, repeat the above steps assuring to press and hold the STOP button within 4 seconds of the motor jog



# Group Control

## 3. Adjusting limits of an individual shade paired on a group channel

To adjust the limits of a shade that is currently grouped on a channel with other shades, it is necessary to place all shades with the exception of the shade to be adjusted, to sleep.

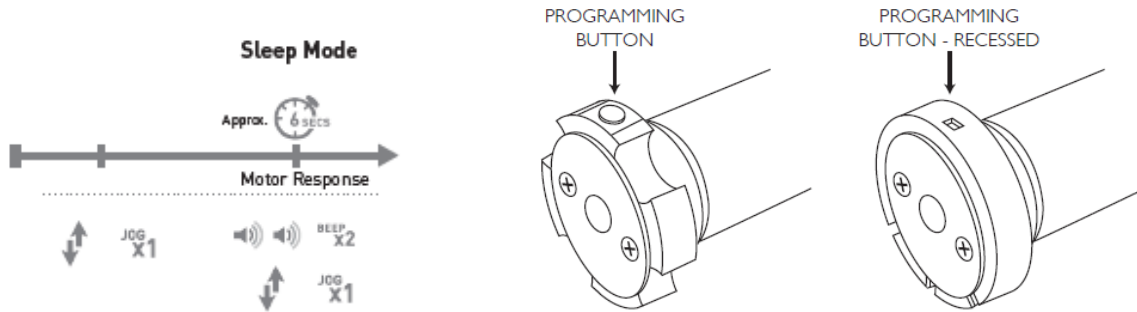

Note: Programming buttons will face down when shade is installed

Once all other shades have been put to sleep, unlock remote by pressing and holding the upper left P2 button under the battery cover until "U" is displayed on the LCD screen. Adjust the shade limits as outlined below:

### ADJUSTING UPPER LIMIT

#### (DELETE Top Limit)

Press UP & STOP (5sec)

Motor Response



Move the shade to the new desired position to be set as limit.

**Important!!** Stop the shade prior to traveling past the desired upper limit

#### (SET Top Limit)

Press UP + STOP (5sec)

Motor Response

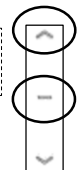

### ADJUSTING LOWER LIMIT

#### (DELETE Lower Limit)

Press DOWN & STOP (5sec)

Motor Response

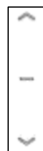

Move the shade to the new desired position to be set as limit.

**Important!!** Stop the shade prior to traveling past the desired lower limit

#### (SET Lower Limit)

Press DOWN + STOP (5sec)

Motor Response



**!!WARNING!!** - Move shade in short increments by pressing the UP/DOWN button in 1 second intervals (pressing the UP/DOWN button for more than 3 seconds may send the shade past desired upper/lower limit and may result in damage to the product). Once you have reached the desired upper/lower limit, you can adjust the limit with either the UP and DOWN buttons. (remember to adjust in short increments!)

Once the limits have been adjusted as desired, return the remote control to "L" mode by pressing and holding the upper left P2 button under the battery cover. The other grouped motors can now be taken out of sleep mode by holding the programming button for 6 seconds

# Reset to Factory Settings

Each Rollease Acmeda battery & plug-in motor will come preprogrammed from the factory. The preprogramming assures the remote is paired with the motor, the upper and lower operation limits are set, the remote is locked and the unnecessary channels are hidden for ease of use (15 available).

Follow the below steps to reset the motor to factory settings and delete all limits.

To reset the shade motor to factory settings with no stored limits locate the P1 button on the motor head. Hold the programming button for 14 seconds. (4 motor jogs)

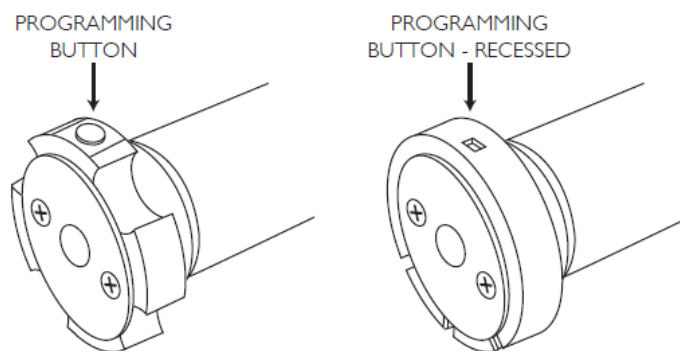

Note: Programming buttons will face down when shade is installed

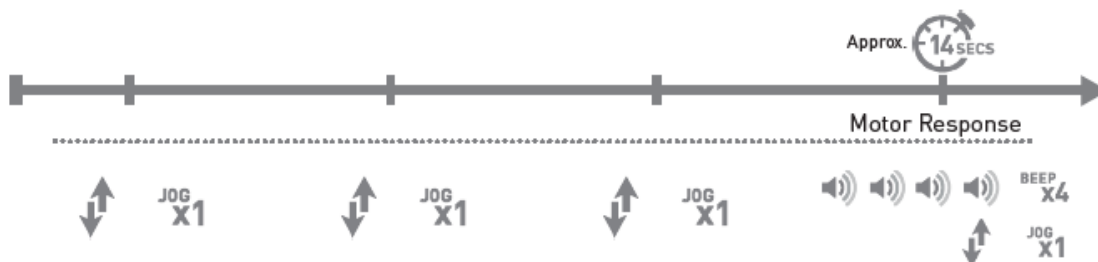

The motor will jog 4 times before the reset is complete. The P1 button must be held the entire time. 4 beeps confirm the factory reset is complete.

Refer to the Initial Setup Programming section to program a shade after a factory reset.

# Troubleshooting

---

<b>PROBLEM</b>	<b>CAUSE</b>	<b>REMEDY</b>
Motor is not responding	Remote battery is discharged	Replace battery
	Battery is inserted incorrectly	Check battery polarity
	Radio interference / Shielding	Ensure remote is positioned away from metal objects and that aerial on motor or receiver is kept straight and away from metal.
	Receiver distance is too far from remote	Move remote to a closer position.
	Power failure	Check power supply to motor is connected and active.
	Incorrect wiring	Check wiring is connected correctly (refer to motor installation instructions)
Cannot set limits on a single Motor (multiple motors respond)	Using "group" channels to adjust motor limits	<p>Always reserve an individual channel for programming functions.</p> <p>SYSTEM BEST PRACTICE – Provide an extra 15 channel remote in your multi motor projects, that provides individual control for each motor for programming purposes.</p>